

Messerschmitt Me P.II Leitwerk



1:72
No. 110

In spite of the nearing end of war started in the Messerschmitt designing department in Oberammergau the design work on two projects of a heavy jet fighter. They were denominated Zerstörer I and II. Due to the shape of the tail area they were denominated also T-Leitwerk. The aircraft had to be efficient and heavily armed machines intended for fighting against bombers. The projecting documentation perished at looting of Messerschmitt's Oberammergau facilities. Only a part of documents was retrieved by US Army intelligence officers.

Navzdory blížícímu se konci války se v Messerschmittově konstrukční kanceláři v Oberammergau rozeběhly konstrukční práce na dvou projektech těžkého tryskového stíhače. Byly označeny Zestörer I a II. Pro tvar ocasních ploch byly také označovány T-Leitwerk. Mělo jít o výkonné a těžce vyzbrojené stroje určené pro boj s bombardéry. Projektová dokumentace vzala za své při drancování závodů Messerschmitt v Oberammergau. Pouze část dokumentace zajistili důstojníci US Army.

A

Messerschmitt Me P.II Leitwerk

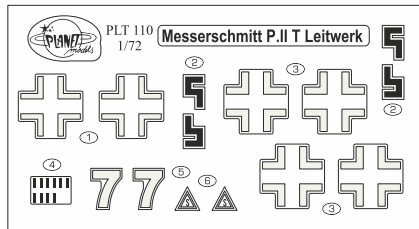
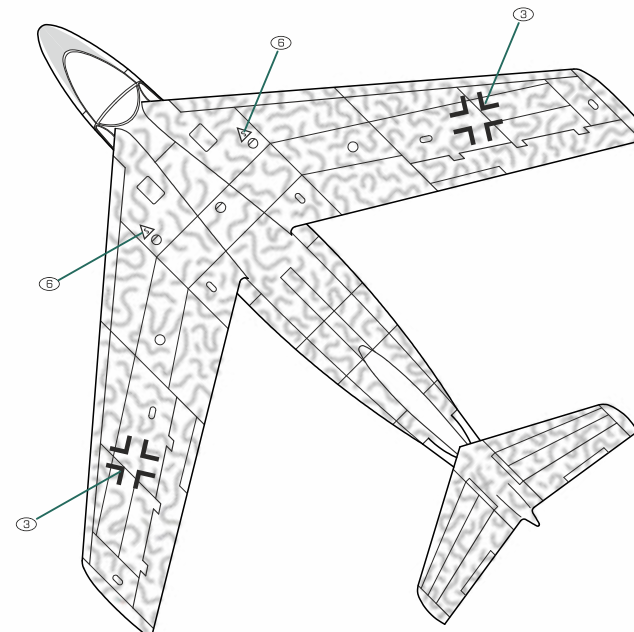
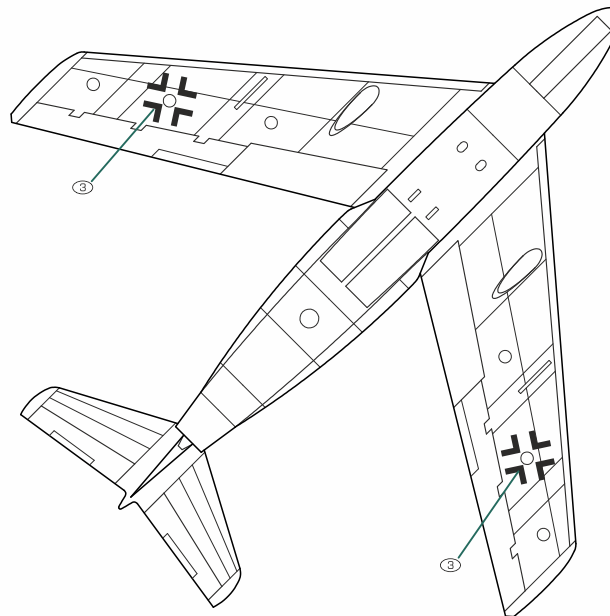
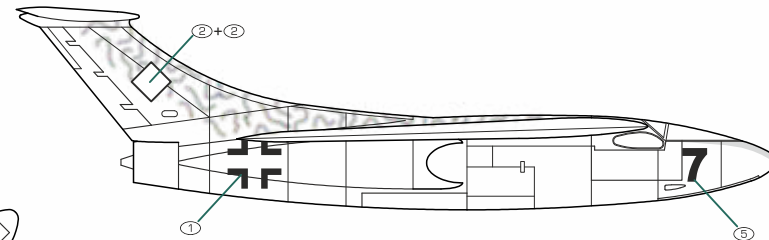
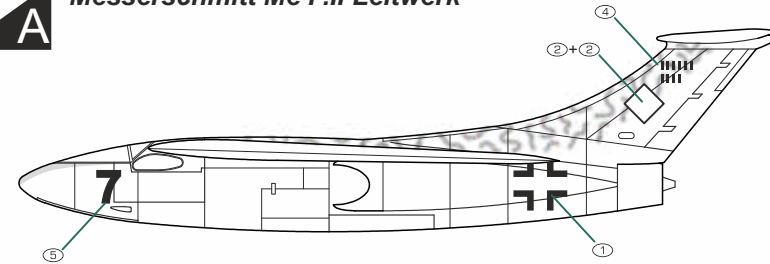

Světlá modrá
Light blue
Lichtblau RLM 76

Šedá
Grey
Grauviolett RLM 75

Použit
kyanoakrylátové lepidlo
For gluing use
cyanoacrylate glue

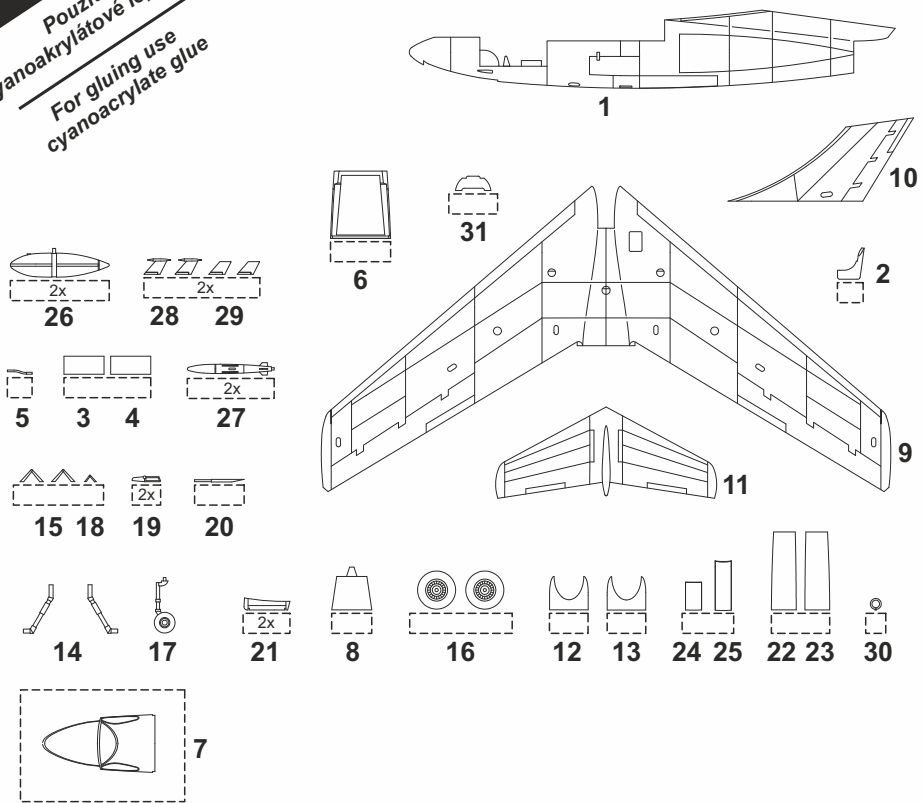

1

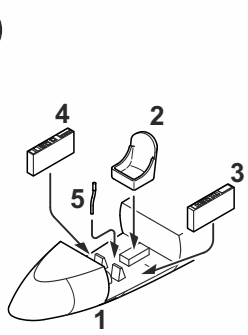

2

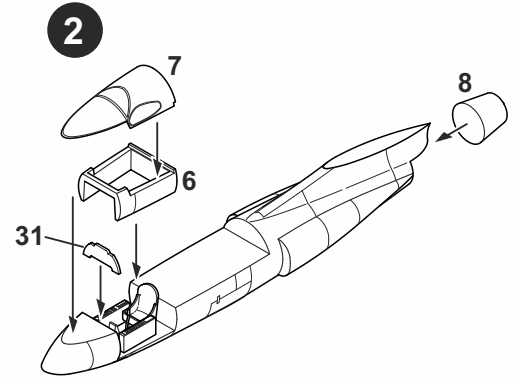

3

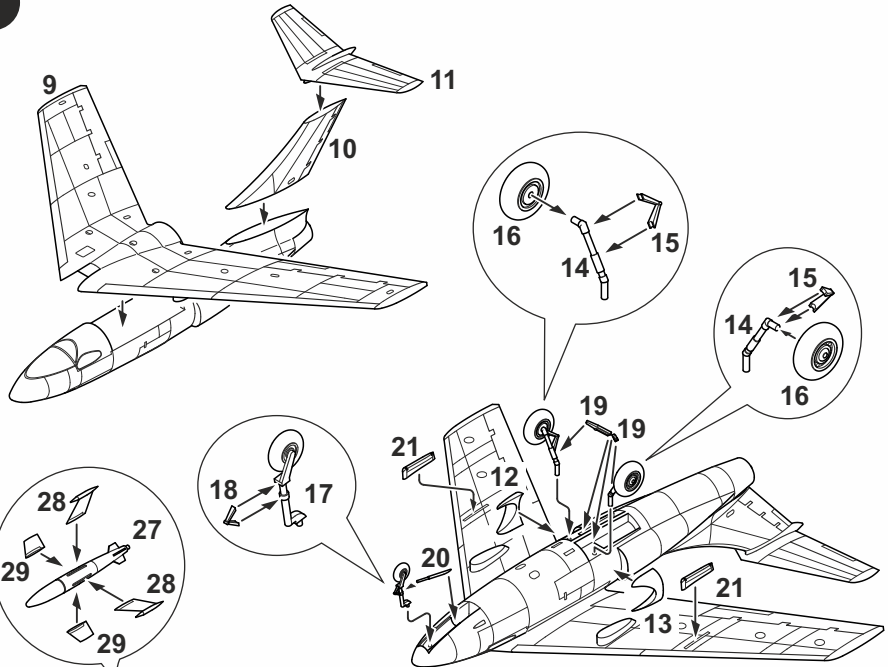

5

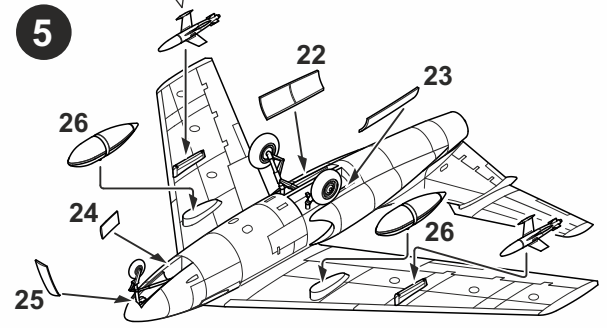

4

6

